

STAND ALONE TORCH LIFTER MUSTAKİL TORC- Z EKSENİ KONTROLÜ

Cap04 + H-Bridge-9 ve CapHB-02L Arabirim Kartı Bağlantı Şeması

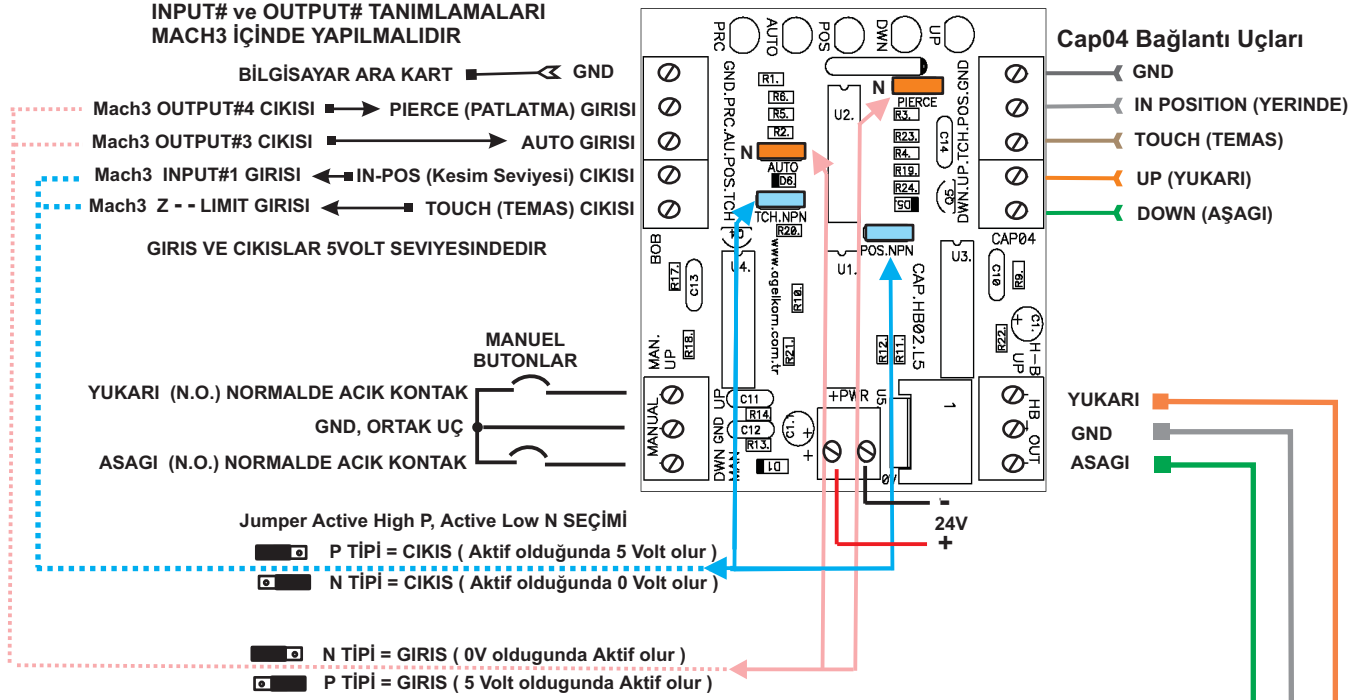

1. GIRIS'LE İLGİLİ "JUMPER" LARIN POZİSYONU LED'LERLE KONTROL EDİLMELİDİR.
2. JUMPER N KISMINDA İKEN PRC, GND İLE KISADEVRE EDİLDİĞİNDE "PRC" ve "UP" LEDLERİ YANAR.
3. AUTO, GND KISA DEVRE İKEN "AUTO" LED'İ YANAR.
4. AUTO MODUNDA, MANUEL "ASAGI" BUTONU DEVRE DISİDİR.
5. MANUEL MODUNDA, Cap04 "ASAGI" SINYALI DEVRE DISİDİR.
6. www.agelkom.com.tr SITESİNDEN M3 VE M5 MAKROLARINI KULLANMANIZ GEREKİR.

